



**Europäisches
Patentamt**

**European
Patent Office**

**Office européen
des brevets**

Urkunde Certificate Certificat

Es wird hiermit bescheinigt, daß für die in der beigefügten Patentschrift beschriebene Erfindung ein europäisches Patent für die in der Patentschrift bezeichneten Vertragsstaaten erteilt worden ist

It is hereby certified that a European patent has been granted in respect of the invention described in the annexed patent specification for the Contracting States designated in the specification.

Il est certifié qu'un brevet européen a été délivré pour l'invention décrite dans le fascicule de brevet ci-joint, pour les États contractants désignés dans le fascicule de brevet

Europäisches Patent Nr.

European Patent No.

Brevet européen n°

1296179

Patentinhaber

Proprietor of the Patent

Titulaire du brevet

Digital Air, Inc.
c/o Calvo Gothelf & Co PC, 875 Sixth Avenue, Suite 2400
New York, NY 10001/US

Alain Pompidou

Präsident des Europäischen Patentamts
President of the European Patent Office
Président de l'Office européen des brevets

München, den 10.11.04
Munich, 10.11.04
Fait à Munich, le

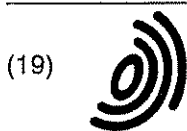

Europäisches Patentamt
European Patent Office
Office européen des brevets



(11) **EP 1 296 179 B1**

(12) **EUROPEAN PATENT SPECIFICATION**

(45) Date of publication and mention
of the grant of the patent:
10.11.2004 Bulletin 2004/46

(51) Int Cl 7: **H04N 5/262, G03B 19/02**

(21) Application number: **02080234.4**

(22) Date of filing: **05.12.1995**

(54) **System for producing time-independent virtual camera movement in motion pictures**

Vorrichtung zur erzeugung von Zeitunabhängigen Virtueller Kamerabewegung in bewegenden Bildern

Système pour obtenir le déplacement virtuel d'une caméra indépendamment du temps dans des films cinématographiques

(84) Designated Contracting States:
AT BE CH DE ES FR GB IT LI NL

(30) Priority: **21.12.1994 US 362653**

(43) Date of publication of application:
26.03.2003 Bulletin 2003/13

(62) Document number(s) of the earlier application(s) in
accordance with Art 76 EPC:
95943374.9 / 0 799 547

(73) Proprietor: **Digital Air, Inc.**
New York, NY 10001 (US)

(72) Inventor: **Taylor, Dayton V.**
1205 - Geneva (CH)

(74) Representative: **Hartley, Andrew Philip et al**
Mathisen, Macara & Co
The Coach House
6-8 Swakeleys Road
Ickenham, Uxbridge UB10 8BZ (GB)

(56) References cited:

EP-A- 0 605 045 **WO-A-92/14341**
US-A- 5 022 727 **US-A- 5 223 925**

- UNKNOWN: "Early Time-Slice Camera"
TIME-SLICE FILM LTD., [Online] pages 1-3,
XP002233793 Retrieved from the Internet:
<URL:www.timeslicefilms.com/cameras_pc.s
html> [retrieved on 2003-03-05]
- UNKNOWN: "Tim Macmillan" TIME-SLICE FILMS
LTD., [Online] pages 1-3, XP002233794
Retrieved from the Internet:
<URL:www.timeslicefilms.com/cv.shtml>
[retrieved on 2003-03-05]
- TIME LIFE: "DIE KAMERA", 1980, TIME-LIFE
INTERNATIONAL (NEDERLAND) B.V.,
NETHERLANDS
- [http://www.bbc.co.uk/cgi-bin/education/betsie/p-
arser.pl](http://www.bbc.co.uk/cgi-bin/education/betsie/p-
arser.pl)

EP 1 296 179 B1

Note: Within nine months from the publication of the mention of the grant of the European patent, any person may give notice to the European Patent Office of opposition to the European patent granted. Notice of opposition shall be filed in a written reasoned statement. It shall not be deemed to have been filed until the opposition fee has been paid. (Art 99(1) European Patent Convention)

Description

[0001] **1. Field of the Invention.** The present invention relates generally to the field of cinematography. More specifically, the present invention discloses a system for producing motion picture scenes that embody time-independent virtual camera movement. An array of specialized modular cameras simultaneously records photographic images of a scene and the resulting photographic images are placed in a motion picture medium and viewed in succession, conveying the illusion that a single camera has moved around a scene frozen in time.

[0002] **2. Statement of the Problem.** Presently, film directors wishing to convey a sense of time passing for the viewer of a scene while time appears stopped for the subject of the same scene, such as might be required in films with science-fiction themes, often find it desirable to freeze the action in the scene while recording the scene with a moving motion picture camera. Scenes so recorded convey the sense of time passing for the viewer, as is naturally inferred from the camera movement, while time appears stopped for the subject.

[0003] Freezing the scene artificially is generally done by making models of any subjects within the scene that would otherwise be in fluid motion and directing actors in the scene to freeze. This method of freezing a scene is obviously limited in scope by a number of factors, particularly if the scene is intended to contain dramatic action. Such factors include the model-maker's ability to portray objects such as fluid properties in motion and the actors' ability to pose without moving. This method is further limited if the scene is documentary in nature, if it involves extensive use of fluids, pyrotechnics, smoke, airborne objects, or other dynamic properties, or if one of the actors is a young child or an animal. In these latter cases, freezing the action artificially is often impossible.

[0004] Another, simpler, method of creating the illusion that time has stopped in a motion picture scene is the freeze-frame. The freeze-frame is an effect achieved by repeating a single frame of camera negative over a series of adjacent frames of a projection print. The resulting composite motion picture image contains absolutely no motion. The freeze-frame is used by some film directors to stop time, usually at a time in the motion picture after the viewer has become accustomed to the general motion and passage of time. By stopping time, the director allows the viewer to reflect on the events that lead up to the stopped moment, as well as the specific drama of that particular moment in time. The freeze-frame, however, is incapable of capturing camera movement, and therefore fails to convey the illusion that time has stopped for the subject of the motion picture but not for the viewer.

[0005] Although subjects have been photographed simultaneously throughout this century for the purpose of recording photographs in three dimensions (i.e., stereo photography), the prior art does not teach or suggest

methods of simultaneous photography for the purpose of creating special time-stopping effects in otherwise conventional motion picture scenes. Nor does the prior art teach or suggest a system for producing virtual camera movement from a sequence of simultaneous still photographs.

[0006] Multiphotographic systems for producing three-dimensional images have been used in the past in a wide variety of other fields, including the following:

Inventor	Patent No	Issue Date
Clay	3,225,651	Dec 28, 1965
Glenn, Jr	3,482,913	Dec 9, 1969
Glenn, Jr	3,508,920	Apr 28, 1970
Glenn, Jr.	3,518,929	July 7, 1970
Matsunaga et al	3,682,064	Aug 8, 1970
Lo et al.	4,037,950	July 26, 1977
Iwane	4,062,045	Dec 6, 1977
Collender	4,158,487	June 19, 1979
Morioka	4,239,359	Dec 16, 1980
Brooks	4,333,715	June 8, 1982
Montes	5,004,335	Apr 2, 1991
Montes	5,013,147	May 7, 1991
Hoppenstein	5,049,987	Sep 17, 1991
Hattori	5,223,925	June 29, 1993
Montes	5,237,353	Aug 17, 1993

[0007] Clay, U.S. Patent No. 3,225,651, discloses a method and apparatus for reproducing a panoramic scene as a three-dimensional image. A plurality of cameras are arranged so that their axes are slightly divergent, with each adjacent pair of cameras producing adjacent stereoscopic images. The images are projected on a special screen consisting of a number of horizontally adjacent viewing cells. The view appears to the audience as a three-dimensional panorama without the use by the audience of special glasses or other assistance.

[0008] Glenn, Jr., U.S. Patent No. 3,482,913, discloses a method for composing and enlarging three-dimensional pictures using a number of projectors each of which is independently adjustable in position and in illumination to provide a high-quality three-dimensional picture.

[0009] Glenn, Jr., U.S. Patent No. 3,508,920, discloses a method for printing high-resolution three-dimensional pictures by producing half-tone pictures in which the width of the half-tone dots is equal to the width of the picture elements and the length of the half-tone dots is several times their width.

[0010] Glenn, Jr., U.S. Patent No. 3,518,929, discloses a camera for producing three-dimensional pictures having a plurality of camera units 11 with a common film spool shaft 21 and shutter drive 40. Each camera unit 11 has its own film guide 19, supply 27, take-up 22

spools, and shutter 16

[0011] Matsunaga et al, U S Patent No 3,682,064, disclose an apparatus for stereographically photographing a scene using a plurality of cameras placed at diverse vantage points relative to the scene. The apparatus includes means for setting the shutter speed for each camera and for either synchronizing or delaying the starting time of the shutter for each camera

[0012] Lo et al, U S Patent No 4,037,950, disclose a method and apparatus to determine and coordinate the variables that bear on the quality of a stereoscopic picture, such as the size of the picture, the distance between adjacent camera vantage points, the camera focal length and the distance from the camera to an element or object in the scene which is to lie in the plane of the picture

[0013] Iwane, U S Patent No 4,062,045, describes a system for producing three-dimensional television images in which a plurality of television cameras are arranged side-by-side in a straight line or arc and the pictures obtained from the cameras are connected to form an angular division distribution pattern from which a three-dimensional image is produced

[0014] Collender U S Patent No 4 158 487, shows a method and apparatus to display both stationary and moving stereoscopic pictures without the need for the observers to use viewing aids

[0015] Morioka, U S Patent No 4,239,359, discloses a method by which an image of an object is projected on a mass to enable the mass to be sculpted into a replica of the original object

[0016] Brooks, U S Patent No 4,333,715, discloses a display structure that can present either two-dimensional or three-dimensional images to a viewer by sequentially activating particular lamps or electrodes to illuminate certain images while leaving unactivated images unobservable. The effect of three-dimensional motion is achieved by sequentially illuminating layers of images in varying positions

[0017] Montes, U S Patent No 5,004,335, shows an apparatus for projecting moving three-dimensional pictures in which the projecting surface emits each photon in a direction determined by the incidence of that photon on the surface. The images for projection are obtained by a series of motion-picture cameras placed adjacent to each other along a straight line

[0018] Montes, U S Patent No 5,013,147, discloses an optical system for three-dimensional reproduction of images in which the images are obtained as described above for Patent no 5,004,335 and the images are displayed by projection on a screen consisting of one layer having vertical cylindrical lenses and a second layer having horizontal cylindrical lenses

[0019] Hoppenstein, U S Patent No 5,049,987, discloses an apparatus for dividing a visual image into separate image strips, transmitting the separate strip images as a composite image, and recreating the visual image as a three-dimensional image by use of a lenticular

lens

[0020] Hattori, U S Patent No 5,223,925, shows an autostereoscopic system that consists of a series of television cameras arranged horizontally that send their images to similarly arranged image output screens that project inverted parallax images through a series of lenses consisting of a first convex lens and then a large Fresnel convex lens

[0021] Montes, U S Patent No 5,237,353, discloses a system for taking, reproducing, and projecting three-dimensional still or moving pictures in which the pictures are taken by groups of two cameras arranged so that their lenses are at right angles and have a semitransparent plate disposed therebetween at a 45-degree angle. The pictures obtained from these groups of cameras are arranged on a single piece of film, which can then be copied or projected. the projection necessitating the use of one-third as many projection lenses as cameras

[0022] In addition to the multiphotographic systems for producing three-dimensional images discussed above prior art exists in the field of image processing for electronically simulating the pan tilt rotation and zoom characteristics of a conventional camera using a single image. For example U S Patent No 5 359.363 of Kuban et al discloses an omniview motionless camera surveillance system that uses a wide angle lens to capture a circular image of an entire field of view in the memory of the device. High speed electronic circuitry can then be employed to view and manipulate a region of interest within the image. The device can accomplish the functions of pan, tilt, rotation, and zoom throughout the field of view without the need for any mechanical mechanisms to move the camera

[0023] A BBC television program, broadcast on 12 May 1993, described an apparatus formed in the shape of a ring and housing a strip of unexposed film. A plurality of pin holes were spaced around an inner surface of the ring. The apparatus was used in darkness by using a flash to illuminate a subject placed in the centre of the ring. After development of the film, the film contained a plurality of images of the subject, each image being from a different viewpoint and corresponding to a respective one of the pin holes. By projecting the film using a cine projector, the film gave the impression of movement of a cine cinema around the subject frozen in time

[0024] **3. Solution to the Problem.** None of the prior art references uncovered in the search show a system for freezing a scene in a moving picture while providing the illusion that the camera is moving in space three dimensionally around the frozen image. The present invention solves this problem by deploying an array of cameras along a preselected path, with each camera focused on a common scene. The cameras simultaneously record a plurality of still images of the scene, and the images thus recorded are transferred in a preselected order to a sequence of frames in a motion picture medium, such as motion picture film or video tape. Because each frame shows the common scene from a dif-

ferent viewpoint, placing the frames in sequence gives the illusion that one camera has moved around a frozen scene (i.e., virtual camera motion). The direction of motion depends on the preselected path chosen, which may be a straight line or any type of curve over which the array of cameras can be deployed.

[0025] Although multiple simultaneous synchronous motion picture cameras are found in the prior art for the purpose of recording three-dimensional motion pictures, none of the prior art references provide a system for combining virtual camera motion (as described above) with motion picture images showing time progression of the scene. A second embodiment of the present invention employs a two-dimensional array of video cameras, each of which synchronously captures a series of images in rapid succession over time. The resulting array of images can be combined in any order to create motion pictures having any desired combination of virtual camera motion and time-sequence images.

SUMMARY OF THE INVENTION

[0026] The present invention provides a system for recording virtual camera movement with respect to a subject at a fixed instant in time. The system uses an array of specialized modular cameras capable of simultaneously recording a number of photographic images of a scene from a number of laterally disposed positions. The system thus produces a series of still photographs that, when viewed in rapid succession as a motion picture, convey the illusion of lateral camera movement with respect to the recorded scene, while the subject of the recorded scene appears stopped in time.

[0027] In one embodiment, the system is formed of a number of still cameras designed to couple with one another so as to provide a continuous light-tight path for a length of photographic film to pass through the entire assemblage of cameras across each camera's focal plane. The system further has a shutter system capable of exposing the film inside all of the cameras simultaneously, light-tight connections for the film to pass to and from film magazines at each end of the assemblage of cameras, a system for advancing the film through the assemblage of cameras from one magazine to another, and a mechanism for moving the entire assemblage in any desired direction during the simultaneous exposure event. Alternatively, an array of video still cameras can be used. The images obtained are subsequently sequentially arranged in a preselected order onto a sequence of frames on motion picture film or video tape. When the motion picture medium is viewed, it appears as though the scene has frozen in time, while the camera appears to move around the frozen subject or scene. In another embodiment, an array of video cameras is used. Each camera in the array synchronously captures a series of images in rapid succession over time. The resulting array of images can be combined and se-

quenced in any order to create motion pictures having a combination of virtual camera motion and time-sequence images.

[0028] A primary object of the present invention is to provide a system that is able to freeze a scene in a motion picture yet provide the illusion of camera movement with respect to the frozen scene.

[0029] Another object of the invention is to provide a system that is capable of combining virtual camera motion with motion picture images showing time progression of the scene.

[0030] Yet another object of the present invention is to provide a system for freezing a scene in a motion picture in which the images comprising the frozen scene embody a blur caused by the movement of the cameras while recording the frozen scene. The motion blur smooths the transition from frame to frame when the motion picture image is reconstituted for viewing by the human eye.

[0031] These and other advantages, features, and objects of the present invention will be more readily understood in view of the following detailed description and the drawings.

[0032] In accordance with a first aspect of the invention, there is provided a system for making a scene for a motion picture, said motion picture having a time base measured in frames per second comprising: an array of cameras deployed along a substantially continuous curve with each camera focused on a common scene; means for repeatedly actuating each of said cameras to capture a respective series of images of the scene over time such that said cameras capture respective images simultaneously with one another; means for transferring said captured images into a random access storage device; means for electronically zooming or panning or tilting selected ones of said captured images; means for creating a motion picture in which said selected zoomed, panned or tilted images are viewed in sequence to create the illusion of progressive camera movement along said curve; and wherein each successive image in said motion picture is captured by a different camera.

[0033] In accordance with a second aspect of the invention there is provided a method for making a scene in a motion picture, said motion picture having a time base measured in frames per second comprising: providing an array of cameras deployed along a substantially continuous curve with each camera focused on a common scene; repeatedly actuating each of said cameras to capture a respective series of images of the scene over time such that said cameras capture respective images simultaneously with one another; transferring said captured images into a random access storage device; electronically zooming or panning or tilting selected ones of said captured images; creating a motion picture in which said selected zoomed, panned or tilted images are viewed in sequence to create the illusion of progressive camera movement along said curve; and wherein each successive image in said motion picture

is captured by a different camera

[0034] In accordance with a third aspect of the invention, there is provided a process for producing virtual progressive camera movement in a motion picture comprising: providing an array of cameras deployed along a preselected path with each camera focused on a common scene; repeatedly actuating each of said cameras to capture a respective series of images of the scene over time such that said cameras capture respective images simultaneously with one another; creating a motion picture in which selected images from said captured images are viewed in sequence to create the illusion of progressive camera movement along the path; and wherein each pair of successive images in said viewed sequence of images combines virtual camera movement and time advancement

BRIEF DESCRIPTION OF THE DRAWINGS

[0035] The present invention can be more readily understood in conjunction with the accompanying drawings, in which:

FIG 1 is a top plan view of a lateral array of cameras of the present invention

FIG 2 is a cross-sectional view of one of the cameras of the present invention

FIG 3 is a top plan view of the present invention showing the lateral array of cameras and the film magazines and shutter trigger

FIG 4 shows an exploded perspective view of a camera of the present invention

FIG 5 is a perspective view of the camera of FIG 4

FIG 6 is a cross-sectional view of the camera of FIG 5

FIG 7(a) and 7(b) are cross-sectional views of a series of cameras of the present invention in straight (a) and curved (b) configurations

FIG 8(a) and (b) show the series of images produced by the cameras of the present invention

FIG 9 illustrates how the images produced by the cameras of the present invention are transferred to a strip of motion picture film

FIG 10 is a block diagram illustrating the steps taken to produce the virtual camera movement of the present invention

FIG 11 is a perspective view of the second embodiment of the series of cameras of the present invention

FIG 12 is a perspective view of one camera of the second embodiment of the present invention showing the lens angles

FIG 13 is a perspective view of one camera of the second embodiment of the present invention

FIG 14 is a perspective view of a portion of the receptacle for the cameras of the second embodiment of the present invention

DETAILED DESCRIPTION OF THE INVENTION

[0036] Turning to FIG 1, an array of cameras 10 of the present invention is seen focused on a common scene 12. A scene 12 as used in this description is not limited to a single point or object but comprehends an entire view or area. The cameras 10 are deployed as desired to achieve a certain effect along a preselected path, for example, a straight line, a concave arcuate path, or a convex arcuate path. As discussed in more detail below, the shape of the path chosen is limited only by the necessity to maintain a light-tight connection between adjacent cameras 10. As with many methods of recording motion pictures, the present invention can be implemented with both photographic film and videotape. Both means of recording motion pictures (photographic film or videotape) are based on the principle of recording and reconstituting multiple frames of still image information in rapid succession continuously over time. Therefore, references to photographic film and motion picture medium are used herein to refer to motion pictures recorded with both photographic emulsion and video recording and storing means, although distinctions between film and videotape are made throughout to indicate the preferred method. Accordingly, it should be evident that either still cameras, video cameras, or motion picture cameras can be used in the array of cameras 10 of the present invention.

[0037] FIG 2 shows a cross section of a single camera 10 of one embodiment of the present invention. The camera 10 is a simple box camera for obtaining still photographs. Light 28 enters the lens 24 and exposes the film 20 at the focal plane 26. A shutter 22 is used to control access of the light 28 to the film 20. It is to be understood that other types of cameras can be used in the present invention, as will be evident to those skilled in the art, for example, motion picture cameras or video cameras, and that the present invention is not meant to be limited to the description of the embodiment shown in FIG 2.

[0038] Illustrated in FIG 3 is an overview of an array of cameras 10 in accordance with the present invention. A series of cameras 10, C_1 to C_N , are arrayed side-by-side. The number C_N of cameras 10 can be varied to suit the needs of the effect one desires to obtain. The cameras 10 are flexibly connected such that a single strip of film 20 passes through all the cameras 10, as can be better appreciated by viewing FIGs 7(a) and 7(b), and as is discussed in more detail below. The film 20 is stored in a first film magazine 30 at one end of the array of cameras 10 and taken up by a second film magazine 32 at the other end of the array of cameras 10. The take-up mechanism 34 can be any conventional mechanism used for taking up film, such as a hand-cranked or machine-driven reel. A shutter release 36 simultaneously controls the shutters 22 for all the cameras 10 in the array. In the preferred embodiment, the shutter release 36 is a mechanical spring-loaded pneu-

matic cylinder using a variable aperture exhaust port to retard the speed of the cocked spring pulling the shutter [0039] The entire array of cameras 10 of the present invention can be moved in any desired direction, for example, laterally as shown by arrow 38, in order to record motion during the simultaneous exposure event. In addition, the flexible array may be attached to a track to maintain the proper optical axis orientation of each module as the array is pushed or pulled to introduce motion blur along a tracking path that is nonlinear and noncircular. The motion blur helps smooth the transition from frame to frame when the motion picture image is reconstituted for viewing by the human eye.

[0040] FIGURES 4 and 5 show a single camera 10 of the present invention. The array of cameras 10 is held tightly together by the tension cables 40, which run through the entire array parallel to and in the same plane as the shutter 22. The shutter 22 is located in a shutter guide 42. The top of the shutter guide 44 serves both to hold the shutter 22 in the shutter guide 42 and to guide the flexible tension cables 40 that hold each camera 10 in place in the array. The lens holder 46, while fulfilling its primary role of supporting the lens 24, also acts to guide and secure the tension cables 40 to the camera body 46. The body 48 of the camera 10 is fitted onto a base 49 having the focal plane 26 therein. A film guide 50 placed between the body 48 and the focal plane 26 holds the film 20 in the correct position against the focal plane 26. The top of the shutter guide 44 and the shutter guide 42 each contain an aperture 52, 54 directing the light path 28 from the lens 24 to the focal plane 26.

[0041] Simultaneity of the shutter 22 release for each camera 10 is achieved in the preferred embodiment by means of a PTFE-coated strip of semi-rigid opaque black film having identical shutter openings 23 cut at intervals equal to the distance between the equidistant lenses of the cameras. This shutter strip 22 travels freely along a path parallel to the film path inside the cameras 10, passing through each camera 10 through the shutter guide 42 on a plane between the camera's lens 24 and aperture 54. The simultaneous exposure event occurs when the shutter strip 22 is pulled a distance less than the distance between two shutter openings 23 (provided this movement starts and stops with the shutter openings 23 out of alignment with the camera apertures 54), so that exactly one shutter opening 23 passes in front of each aperture 54 during the event being recorded. This results in a simultaneous and identical time-length exposure of the film 20 inside each of the cameras 10 in the array. The shutter strip 22 could be pulled by, for example, a spring-loaded pneumatic cylinder 36 as discussed above and illustrated in FIG. 3. It should be understood that other systems of shutters providing simultaneity will be evident to those skilled in the art. After each simultaneous exposure event, the film 20 contained inside the array of cameras 10 is advanced into the second magazine 32, pulling a fresh strip of unexposed film 20 out of the first magazine 30 and into the

array of cameras 10, which are then ready for the next simultaneous exposure event.

[0042] The light-tight coupling between cameras 10 comprises a telescoping, double-overlapping light-tight connection, as shown in FIGs. 6 and 7(a) and 7(b). At one side of the camera 10 are found two flanges 60 and 61 on either side of the film 20 that are inserted in corresponding spaces 62 and 63 on an adjacent camera 10 as shown in FIG. 7(a). The size of spaces 62 and 63 is exaggerated in the figures for ease of viewing. Space 63 is formed by two flanges 64 and 65. Flange 61 has at its outermost edge an outward-protruding lip 67. Flange 65 has at its outermost edge an inward-protruding lip 66. When two cameras 10 are situated adjacently as shown in FIG. 7(a), the outward-protruding lip 67 fits into space 63 over flange 65 and the inward-protruding lip 66, forming a light-tight connection beneath the path of the film 20. Another light-tight connection is formed by the insertion of flange 60 into space 62 above the path of the film 20. A further light-tight flexible joint is formed on the shutter plane around the shutter strip 22 by the juxtaposition of flanges 70, 71, 72, and 73.

[0043] A further advantage of the light-tight connections described above for the preferred embodiment of the present invention is their ability to remain light-tight when the array of cameras 10 is deployed on an arc or circle as described above in FIG. 1 and as shown in more detail FIG. 7(b). FIG. 7(a) shows the array deployed on a straight line, whereas FIG. 7(b) illustrates the changes that occur when the array of cameras 10 is curved on an arc. As the shutter 22 moves a distance A (as shown by arrows 74), the outward-protruding lip 67 moves a distance B (as shown by arrows 75) until it abuts the inward-protruding lip 66, at which point further telescoping of the connection is prevented. The overlapping lips 66 and 67 maintain the light-tight integrity of the connection during the deployment of the cameras 10 on an arc.

[0044] FIGS. 8(a) and 8(b) illustrate the images recorded by a straight-line array of cameras 10. The cameras 10 (80 through 84) are positioned to record a common scene 12. The dotted lines show the light path 28 seen by each camera 10. During a simultaneous recording event, each camera 10 records an image on the strip of film 20, as shown by images 80 through 84 in FIG. 8(b). As a result of the placement of each camera 10 (80 through 84), the perspective of each image 80 through 84 recorded shifts so that when the frames 80 through 84 are viewed in succession in, for instance, a motion picture, the viewer has the impression that a single motion picture camera is moving around the scene 12 while the scene 12 remains frozen in time.

[0045] The process that moves the images recorded by the cameras 10 of the system of the present invention from the film 20 to a motion picture medium, either motion picture film or videotape, is illustrated in FIG. 9. A series of negatives are recorded on the film 20. During the process that moves the negatives from the film 20

to the final motion picture medium, each negative is rotated 90 degrees as shown in FIG 9 and placed in the order desired on a motion picture or video medium 90 that will eventually be part of a motion picture. The process can be performed by optically transferring and rotating the film negatives in the conventional manner. Alternatively, the process can be performed as illustrated in FIG 10. An original camera negative 1002 is digitized onto a photo compact disk 1004 (CD). The CD 1004 is then accessed by use of a computer workstation 1006, where the digitized images 1002 are rotated or otherwise manipulated and then assembled to achieve the effect of virtual camera motion. Finally, the assembled images are recorded to motion picture film or videotape 1008. A system currently available for performing the process described above is the Kodak Cineon digital film system of the Eastman Kodak Co., Rochester, New York.

[0046] It should be noted that other digital storage mediums, such as magnetic or optical disks, could be used to store images in place of photo compact disks. Random access devices, such as magnetic or optical disks, provide great flexibility for the user in selecting, combining, and editing images. Random access devices also facilitate creation of multimedia applications incorporating image sequences. Interactive computer applications often use image sequences in a non-linear manner, unlike conventional motion pictures or videotape.

[0047] The present system is capable of recording a series of simultaneous exposure events over time, in addition to recording a single simultaneous exposure event. Specifically, the method, when utilized in rapid succession, records forward-in-time sequences of images that embody a recordation of the advance of time within the scene, as well as lateral-in-space sequences of images that embody a recordation of lateral virtual camera movement. The time base of the lateral virtual camera movement is independent of the time base of the scene itself. Such a time-series of images would present the effect, when selected and sequenced into a motion picture or video medium as described in more detail below, of showing advancing time in the scene in addition to lateral virtual camera motion.

[0048] A second embodiment of the present invention is illustrated in FIGs 11 through 14. The apparatus of the second embodiment employs an array of video cameras 1100 as shown in FIG. 11 capable of recording a plurality of photographic images of a scene from a plurality of positions simultaneously and synchronously in rapid succession over time. Compared with the first embodiment, the user can choose any sequence of images desired from the array of recorded images. This provides the user with complete flexibility to combine images from any of the cameras in the array 1100, including sequences recorded along a path within the camera array at a fixed point in time, as in the first embodiment. For example, the user can select a sequence of fixed-in-time images from a single row or column of individual

cameras or any other desired pattern available within the array shown in FIG 11. The user can also select forward-in-time sequences of images from selected cameras, or backward-in-time sequences, or any other combination of fixed-in-time and time-sequence images. This embodiment allows user-controllable virtual camera movement with the respect to the scene as time advances.

[0049] Each individual video camera 1102, illustrated in FIG 12, captures an extremely wide field of view, as shown by arrows 1200, that is recorded digitally and that can be electronically zoomed, panned, and tilted, or otherwise edited as desired after recordation. To form the array of video cameras, each individual camera 1102 is mounted in a receptacle 1400 as shown in FIG 14 having a plurality of holes 1402 cut therein to receive the cameras 1102. Each hole 1402 has a tongue 1404 extending toward its center that matches a corresponding groove 1302 cut into the casing 1300 of each video camera 1102, as can be seen in FIG 13. The tongue-and-groove arrangement both secures the cameras 1102 and aligns them all at the same predetermined degree as a benchmark for the image recorded from each camera 1102. The receptacle 1400 is formed of a flexible material that can be bent into a desired shape depending on the effect to be achieved, for example, an arc as shown in FIG 11.

[0050] This flexibility enables the system of the second embodiment of the present invention to generate virtual camera movement in nearly any direction rather than simply along a linear path as described above for the preferred embodiment. Here again, the entire array of images can be stored on a random access storage device to simplify selection, editing and sequencing by the user.

[0051] The above disclosure sets forth a number of embodiments of the present invention. Other arrangements or embodiments, not precisely set forth, could be practiced under the teachings of the present invention and as set forth in the following claims.

Claims

1. A system for making a scene in a motion picture, said motion picture having an time base measured in frames per second, comprising:

an array of cameras (10, 1102) deployed along a substantially continuous curve with each camera focused on a common scene;
means (22) for repeatedly actuating each of said cameras (10, 1102) to capture a respective series of images of the scene over time such that said cameras capture respective images simultaneously with one another;
means for transferring said captured images into a random access storage device;

- means for electronically zooming or panning or tilting selected ones of said captured images; means for creating a motion picture in which said selected zoomed panned or tilted images are viewed in sequence to create the illusion of progressive camera movement along said curve;
- and wherein each successive image in said motion picture is captured by a different camera (10, 1102).
2. A method for making a scene in a motion picture, said motion picture having a time base measured in frame per second, comprising:
- providing an array of cameras (10, 1102) deployed along a substantially continuous curve with each camera focused on a common scene; repeatedly actuating each of said cameras (10, 1102) to capture a respective series of images of the scene over time such that said cameras capture respective images simultaneously with one another;
- transferring said captured images into a random access storage device;
- electronically zooming or panning or tilting selected ones of said captured images;
- creating a motion picture in which said selected zoomed panned or tilted images are viewed in sequence to create the illusion of progressive camera movement along said curve;
- and wherein each successive image in said motion picture is captured by a different camera (10, 1102).
3. A system according to claim 1 or a method according to claim 2, wherein said substantially continuous curve is substantially disposed in a single plane
4. A system according to claim 1 or a method according to claim 2, wherein said plurality of cameras (10, 1102) are disposed adjacent and superior to each other
5. A system according to claim 1 or a method according to claim 2, wherein said substantially continuous curve is of an infinite radius
6. A system according to claim 1 or a method according to claim 2, wherein said images are captured by a motion picture film (20)
7. A system according to claim 1 or a method according to claim 2, wherein said images are captured by a video recording device
8. A system according to claim 1 or a method according to claim 2, wherein said motion picture comprises one image from each of said cameras (10, 1102)
9. A process for producing virtual progressive camera movement in a motion picture comprising:
- providing an array of cameras (10, 1102) deployed along a preselected path with each camera focused on a common scene;
- repeatedly actuating each of said cameras (10, 1102) to capture a respective series of images of the scene over time such that said cameras capture respective images simultaneously with one another;
- creating a motion picture in which selected images from said captured images are viewed in sequence to create the illusion of progressive camera movement along the path;
- and wherein each pair of successive images in said viewed sequence of images combines virtual camera movement and time advancement.
10. A process according to claim 9, wherein said creation includes editing the selected images
11. A motion picture produced by the process of claim 2 or claim 9

Patentansprüche

1. System zum Herstellen einer Szene in einer Kinoaufnahme, wobei die Kinoaufnahme eine Zeitbasis hat, die in Einzelbildern pro Sekunde gemessen wird, und das umfasst:
- eine Anordnung von Kameras (10, 1102), die entlang eines im Wesentlichen durchgehenden Bogens aufgestellt sind, wobei jede Kamera auf eine gemeinsame Szene fokussiert ist;
- eine Einrichtung (22), die jede der Kameras (10, 1102) wiederholt betätigt, um mit der Zeit eine entsprechende Reihe von Bildern der Szene so zu erfassen, dass die Kameras entsprechende Bilder simultan zueinander erfassen;
- eine Einrichtung, die die erfassten Bilder in eine Direktzugriffsspeichervorrichtung überträgt;
- eine Einrichtung, die ausgewählte der erfassten Bilder elektronisch skaliert oder schwenkt oder neigt;

- eine Einrichtung, die eine Kinoaufnahme schafft, in der die ausgewählten skalierten, geschwenkten oder geneigten Bilder in Abfolge betrachtet werden, um die Illusion fortlaufender Kamerabewegung entlang des Bogens zu erzeugen; und
- wobei jedes aufeinander folgende Bild in der Kinoaufnahme von einer anderen Kamera (10, 1102) erfasst wird
2. Verfahren zum Herstellen einer Szene in einer Kinoaufnahme, wobei die Kinoaufnahme eine Zeitbasis hat, die in Einzelbildern pro Sekunde gemessen wird, und das umfasst:
- Bereitstellen einer Anordnung von Kameras (10, 1102), die entlang eines im Wesentlichen durchgehenden Bogens aufgestellt sind, wobei jede Kamera auf eine gemeinsame Szene fokussiert ist;
- wiederholtes Betätigen jeder der Kameras (10, 1102), um mit der Zeit eine entsprechende Reihe von Bildern der Szene so zu erfassen, dass die Kameras entsprechende Bilder simultan zueinander erfassen;
- Übertragen der erfassten Bilder in eine Direktzugriffsspeichervorrichtung;
- elektronisches Skalieren oder Schwenken oder Neigen ausgewählter der erfassten Bilder;
- Schaffen einer Kinoaufnahme, in der die ausgewählten skalierten, geschwenkten oder geneigten Bilder in Abfolge betrachtet werden, um die Illusion fortlaufender Kamerabewegung entlang des Bogens zu erzeugen; und
- wobei jedes aufeinander folgende Bild in der Kinoaufnahme von einer anderen Kamera (10, 1102) erfasst wird
3. System nach Anspruch 1 oder Verfahren nach Anspruch 2, wobei der im Wesentlichen durchgehende Bogen im Wesentlichen in einer Ebene angeordnet ist
4. System nach Anspruch 1 oder Verfahren nach Anspruch 2, wobei die Vielzahl von Kameras (10, 1102) aneinander angrenzend und übereinander angeordnet sind
5. System nach Anspruch 1 oder Verfahren nach Anspruch 2, wobei der im Wesentlichen durchgehende Bogen einen unendlichen Radius hat
6. System nach Anspruch 1 oder Verfahren nach Anspruch 2, wobei die Bilder mit einem Kinofilm (20) erfasst werden.
7. System nach Anspruch 1 oder Verfahren nach Anspruch 2, wobei die Bilder mit einer Videoaufzeichnungsvorrichtung erfasst werden
8. System nach Anspruch 1 oder Verfahren nach Anspruch 2, wobei der Film ein Bild von jeder der Kameras (10, 1102) umfasst
9. Prozess zum Erzeugen virtueller fortlaufender Kamerabewegung in einer Kinoaufnahme, der umfasst:
- Bereitstellen einer Anordnung von Kameras (10, 1102), die entlang eines vorgewählten Weges aufgestellt sind, wobei jede Kamera auf eine gemeinsame Szene fokussiert ist;
- wiederholtes Betätigen jeder der Kameras (10, 1102), um mit der Zeit eine entsprechende Reihe von Bildern der Szene so zu erfassen, dass die Kameras entsprechende Bilder simultan zueinander erfassen;
- Schaffen einer Kinoaufnahme, in der ausgewählte Bilder der erfassten Bilder in Abfolge betrachtet werden, um die Illusion fortlaufender Kamerabewegung entlang des Weges zu erzeugen;
- und wobei jedes Paar aufeinander folgender Bilder in der betrachteten Reihenfolge von Bildern virtuelle Kamerabewegung und Zeitablauf kombiniert
10. Verfahren nach Anspruch 9, wobei das Schaffen das Editieren der ausgewählten Bilder einschließt
11. Kinofilm, der mit dem Verfahren nach Anspruch 2 oder Anspruch 9 hergestellt wird

Revendications

1. Système pour constituer une scène dans une image mobile, ladite image mobile présentant une base de temps qui est mesurée en images par seconde, comprenant :
- un réseau de caméras (10, 1102) qui est déployé le long d'une courbe sensiblement continue, chaque caméra étant focalisée sur une scène commune ;
- un moyen (22) pour actionner de façon répétée chacune desdites caméras (10, 1102) afin de

- capturer une série respective d'images de la scène au fil du temps de telle sorte que lesdites caméras capturent des images respectives simultanément les unes par rapport aux autres ; un moyen pour transférer lesdites images capturées dans un dispositif de stockage sous forme de mémoire vive ; un moyen pour, de façon électronique, réaliser un effet de zoom ou de panoramique ou d'inclinaison de celles sélectionnées desdites images capturées ; un moyen pour créer une image mobile dans laquelle lesdites images sélectionnées soumises à effet de zoom, de panoramique ou d'inclinaison sont vues en séquence afin de créer l'illusion d'un déplacement de caméra progressif le long de ladite courbe ; et
- dans lequel chaque image successive dans ladite image mobile est capturée par une caméra différente (10, 1102)
2. Procédé pour constituer une scène dans une image mobile, ladite image mobile présentant une base de temps qui est mesurée en images par seconde, comprenant :
- la fourniture d'un réseau de caméras (10, 1102) qui est déployé le long d'une courbe sensiblement continue, chaque caméra étant focalisée sur une scène commune ; l'actionnement de façon répétée de chacune desdites caméras (10, 1102) afin de capturer une série respective d'images de la scène au fil du temps de telle sorte que lesdites caméras capturent des images respectives simultanément les unes par rapport aux autres ; le transfert desdites images capturées dans un dispositif de stockage sous forme de mémoire vive ; la réalisation de façon électronique, d'un effet de zoom ou de panoramique ou d'inclinaison sur celles sélectionnées desdites images capturées ; la création d'une image mobile dans laquelle lesdites images sélectionnées soumises à effet de zoom, de panoramique ou d'inclinaison sont vues en séquence afin de créer l'illusion d'un déplacement de caméra progressif le long de ladite courbe ; et
- dans lequel chaque image successive dans ladite image mobile est capturée par une caméra différente (10, 1102)
3. Système selon la revendication 1 ou procédé selon la revendication 2, dans lequel ladite courbe sensiblement continue est sensiblement disposée dans un unique plan.
4. Système selon la revendication 1 ou procédé selon la revendication 2, dans lequel les caméras de ladite pluralité de caméras (10, 1102) sont disposées de manière à être adjacentes les unes aux autres et plus hautes les unes que les autres.
5. Système selon la revendication 1 ou procédé selon la revendication 2, dans lequel ladite courbe sensiblement continue est d'un rayon infini.
6. Système selon la revendication 1 ou procédé selon la revendication 2, dans lequel lesdites images sont capturées au moyen d'un film cinématographique (20)
7. Système selon la revendication 1 ou procédé selon la revendication 2, dans lequel lesdites images sont capturées au moyen d'un dispositif d'enregistrement vidéo
8. Système selon la revendication 1 ou procédé selon la revendication 2, dans lequel ladite image mobile comprend une image en provenance de chacune desdites caméras (10, 1102)
9. Procédé pour produire un déplacement virtuel progressif de caméra dans une image mobile, comprenant :
- la fourniture d'un réseau de caméras (10, 1102) qui est déployé le long d'une voie présélectionnée, chaque caméra étant focalisée sur une scène commune ; l'actionnement de façon répétée de chacune desdites caméras (10, 1102) afin de capturer une série respective d'images de la scène au fil du temps de telle sorte que lesdites caméras capturent des images respectives simultanément les unes par rapport aux autres ; la création d'une image mobile dans laquelle des images sélectionnées parmi lesdites images capturées sont visualisées en séquence afin de créer l'illusion d'un déplacement progressif de caméra le long de la voie ; et
- dans lequel chaque paire d'images successives dans ladite séquence visualisée d'images combine un déplacement virtuel de caméra et une avancée temporelle afférente
10. Procédé selon la revendication 9, dans lequel ladite création inclut l'édition des images sélectionnées
11. Image mobile produite au moyen du procédé selon la revendication 2 ou 9

Fig. 1

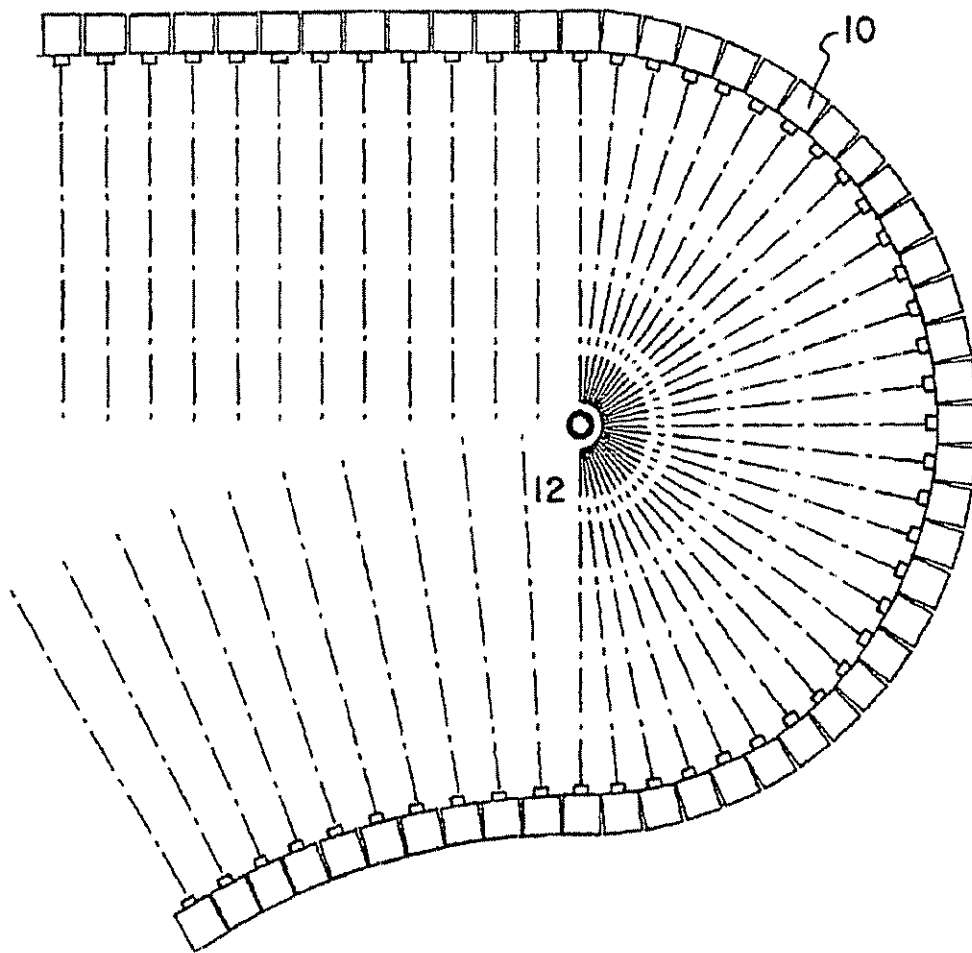

Fig. 2

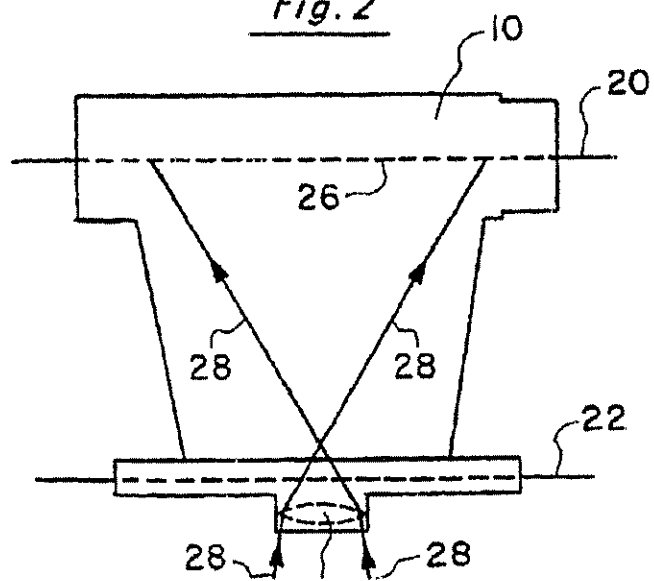

Fig. 3

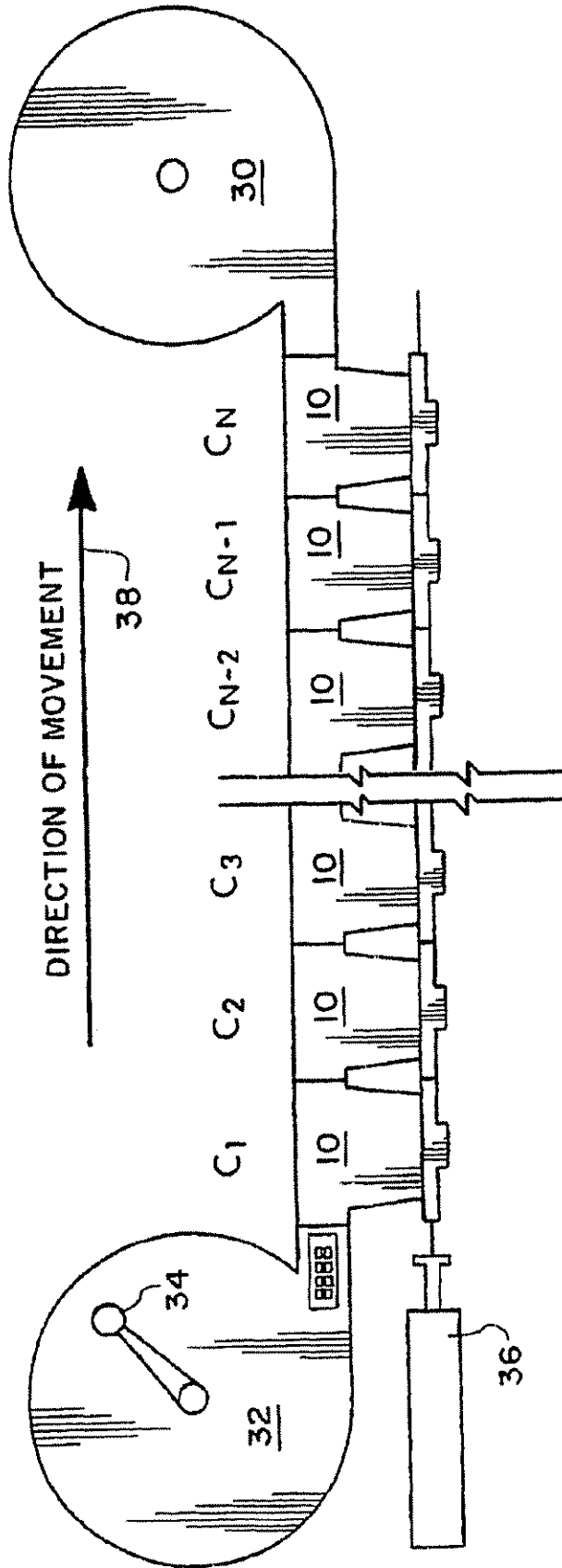
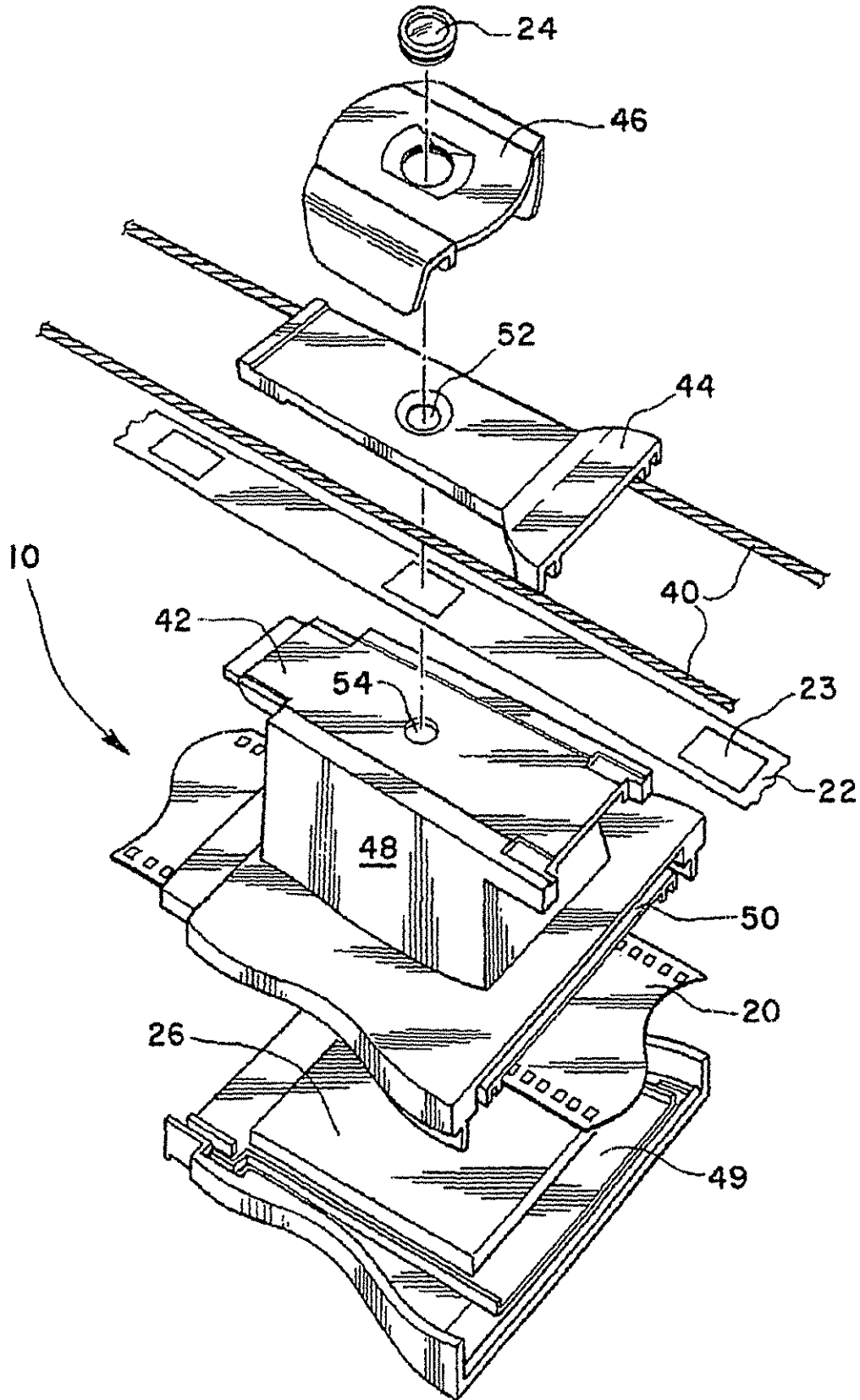
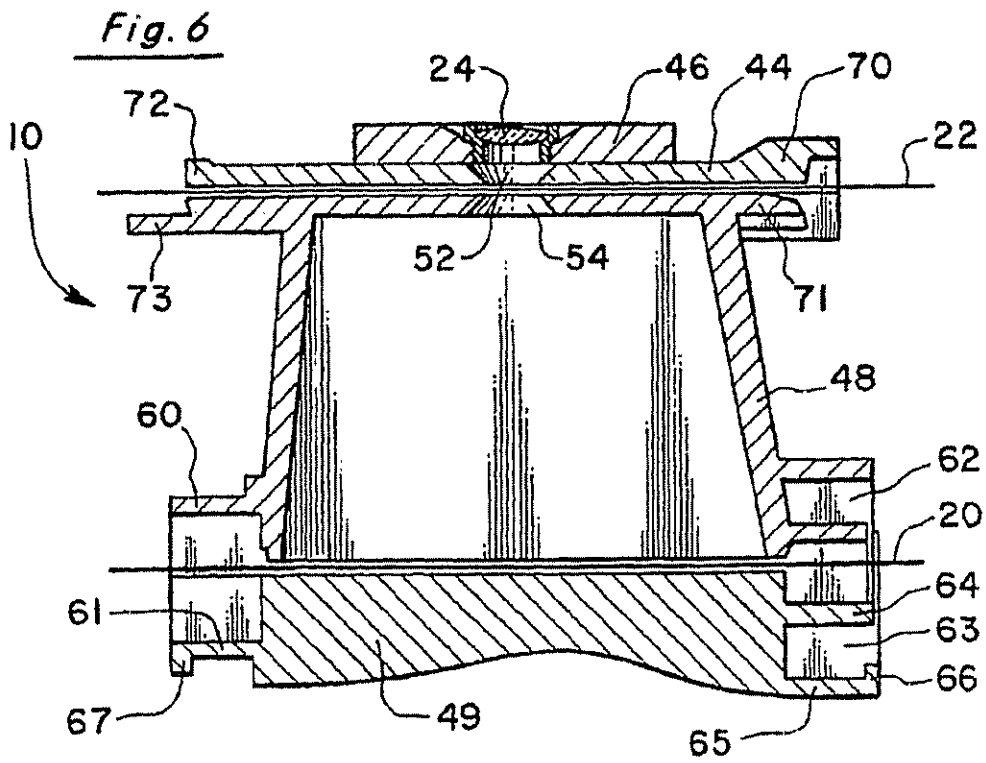
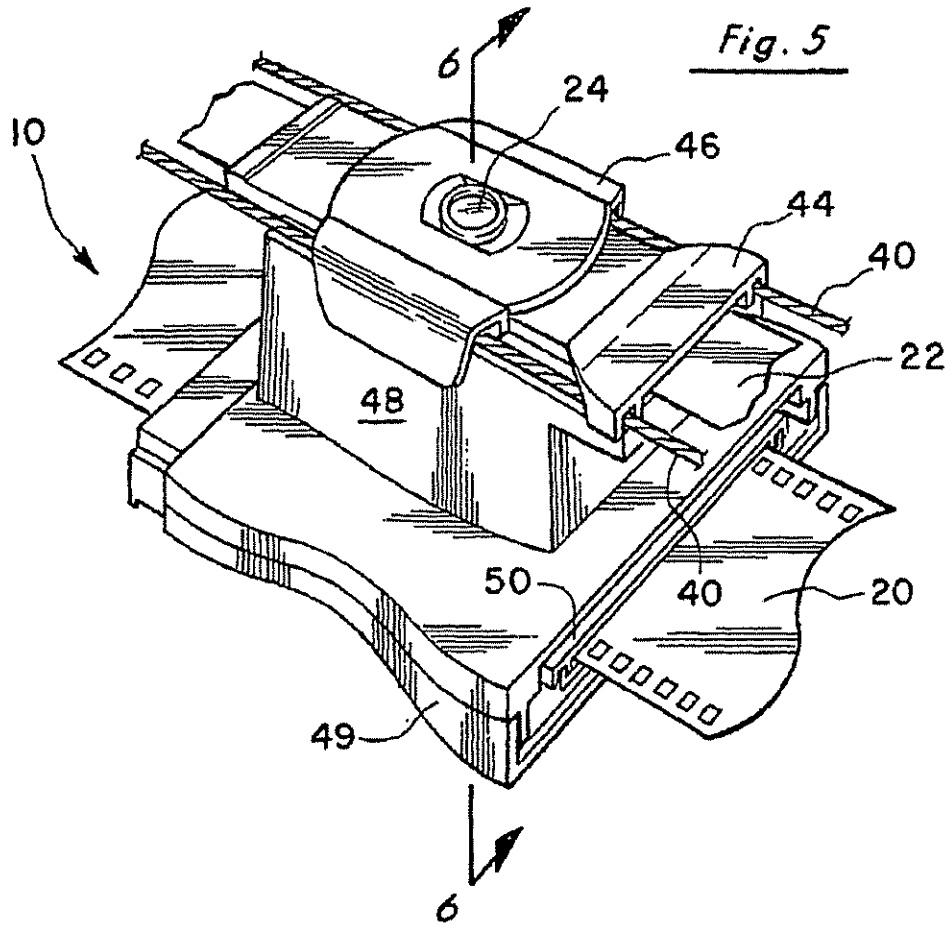

Fig. 4





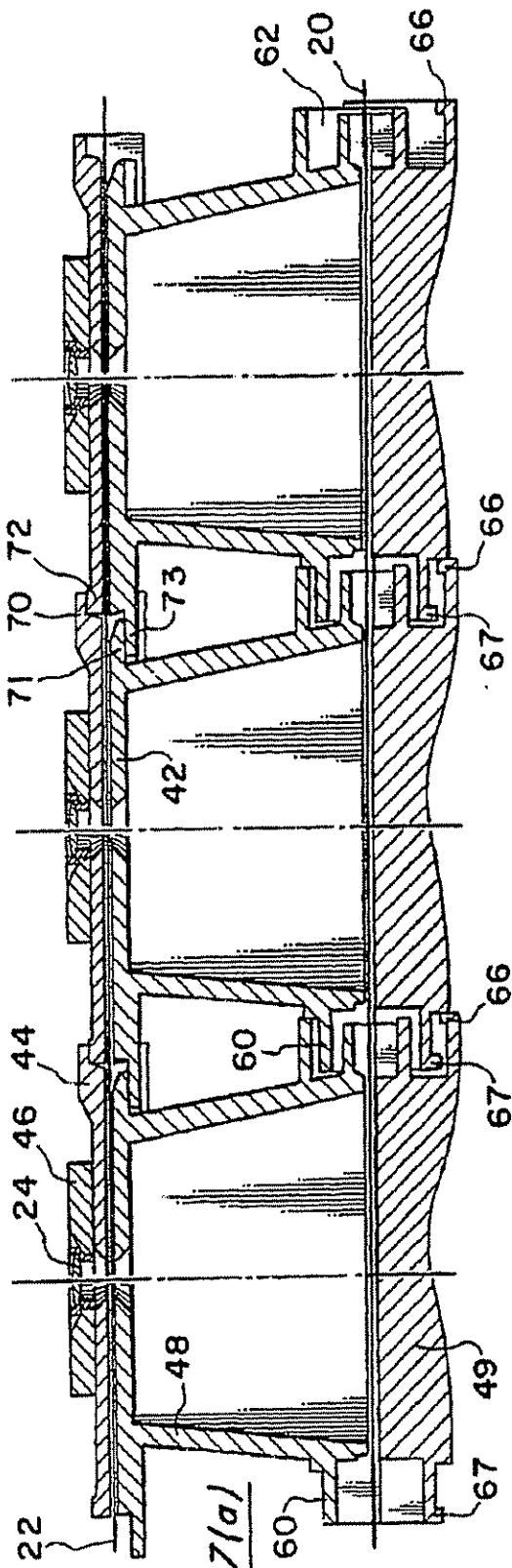

Fig. 7(a)

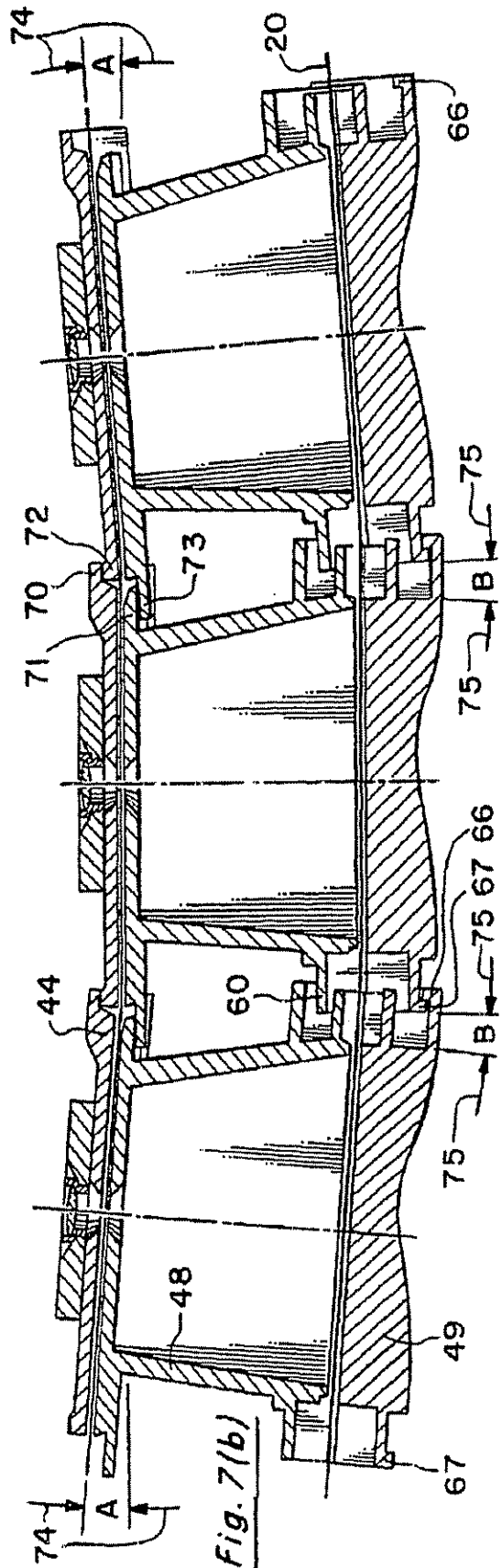

Fig. 7(b)

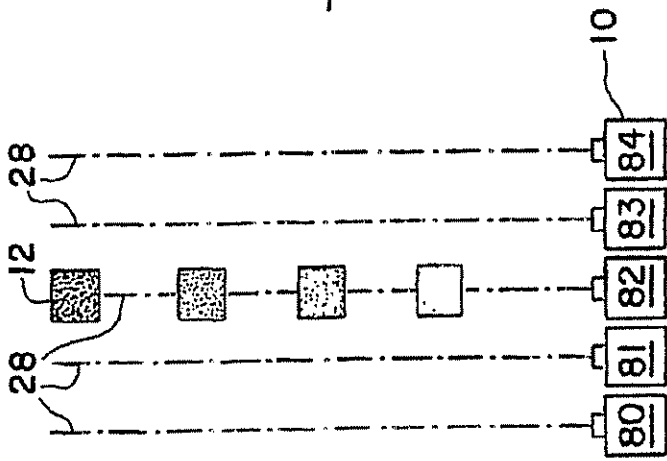

Fig. 8(a)

Fig. 8(b)

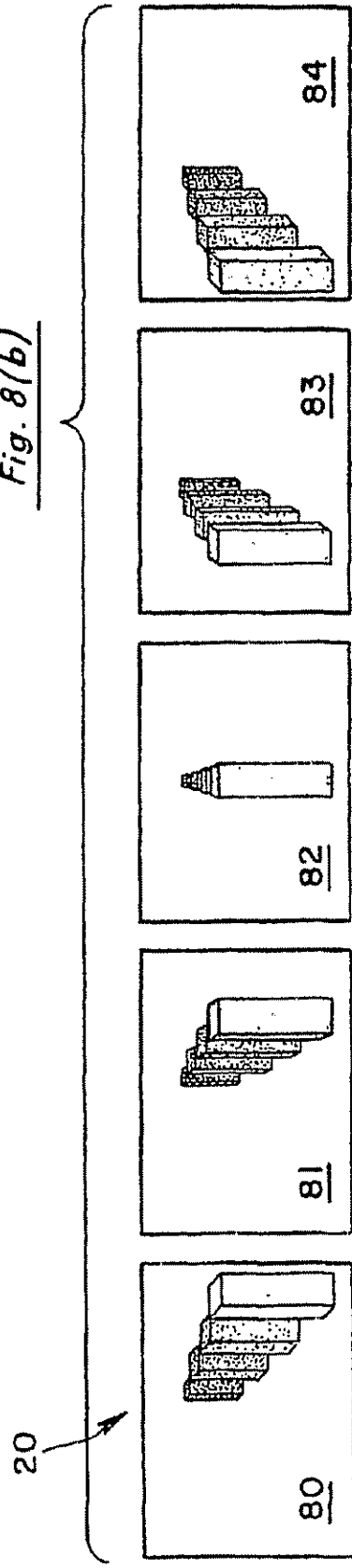

Fig. 9

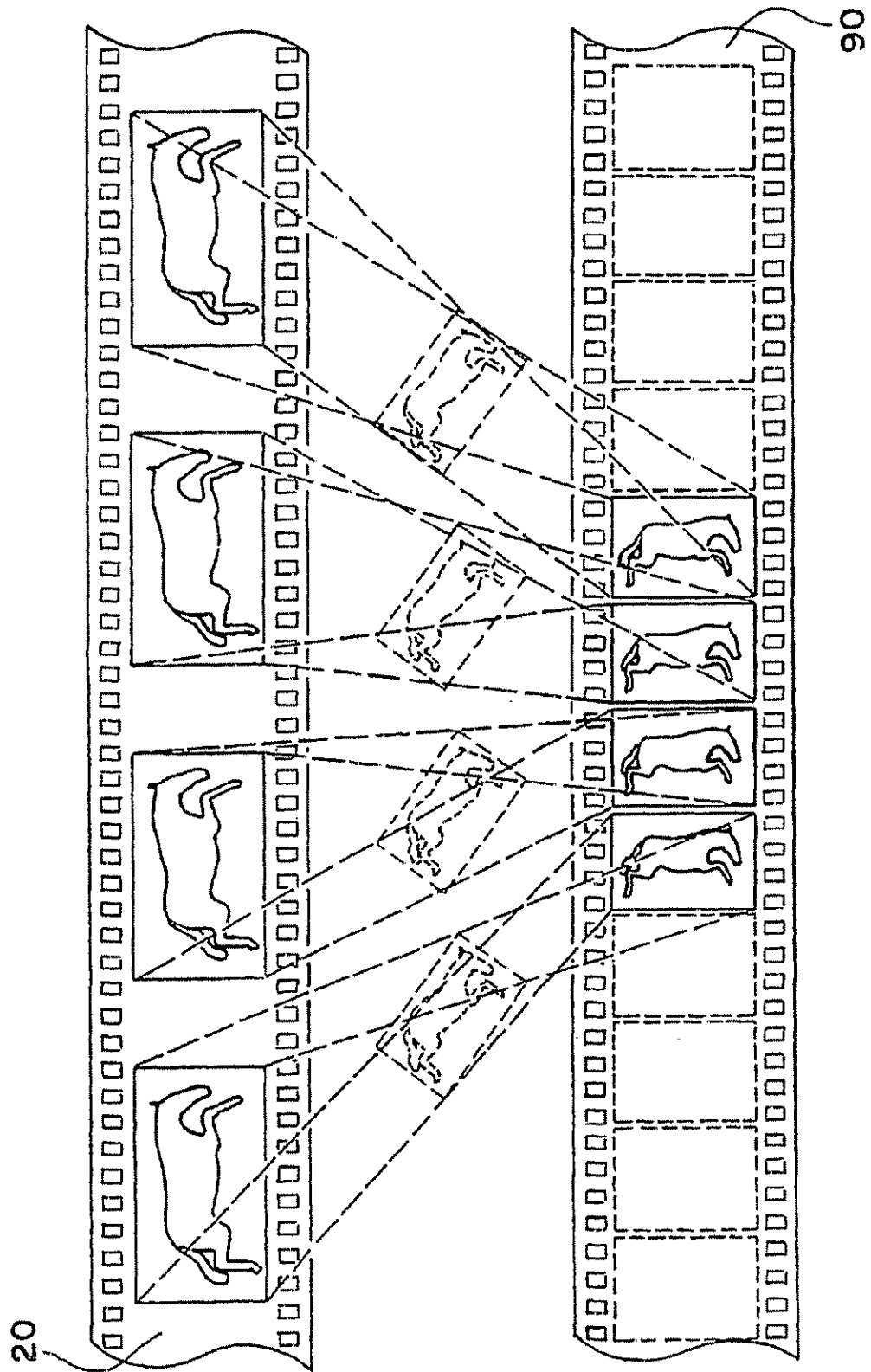

Fig. 10

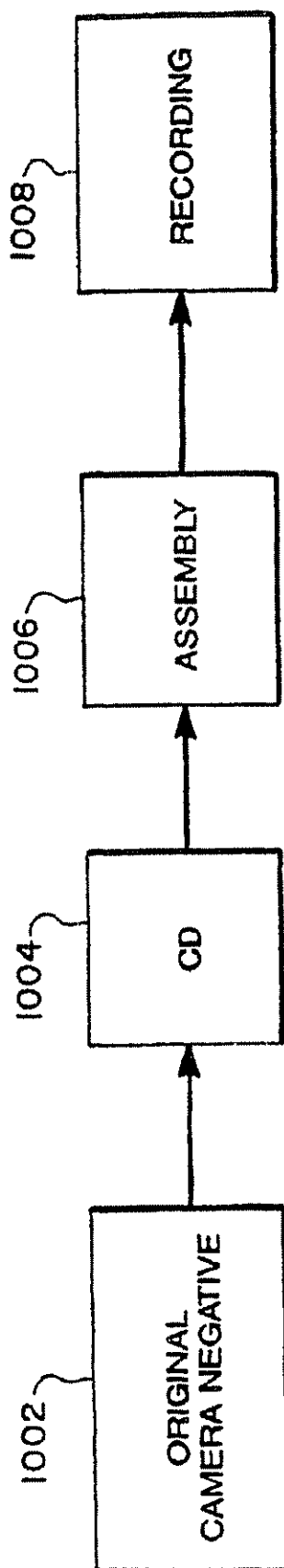

Fig. 11

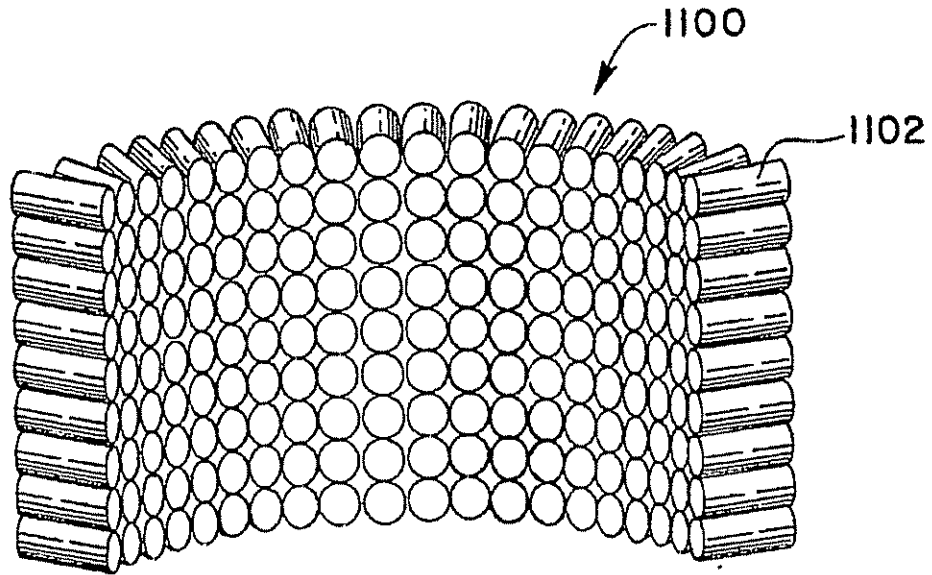
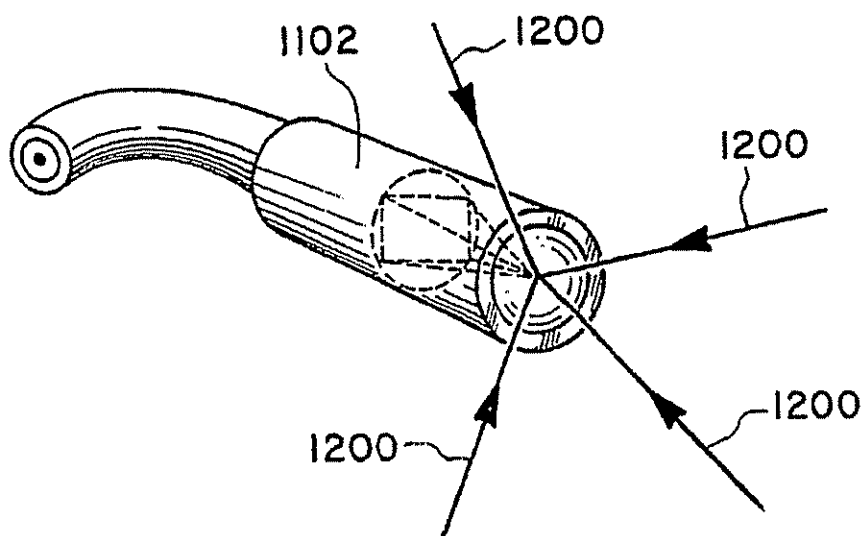

Fig. 12



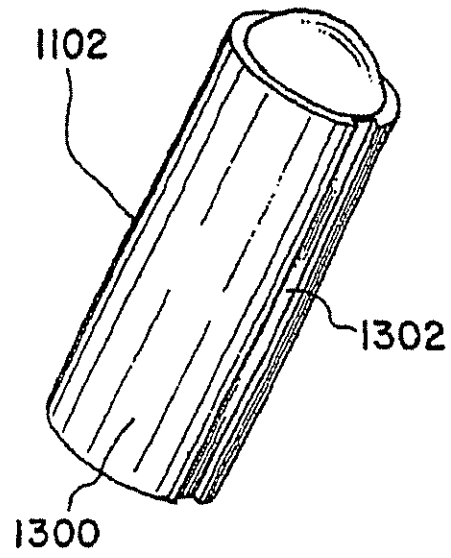

Fig. 13

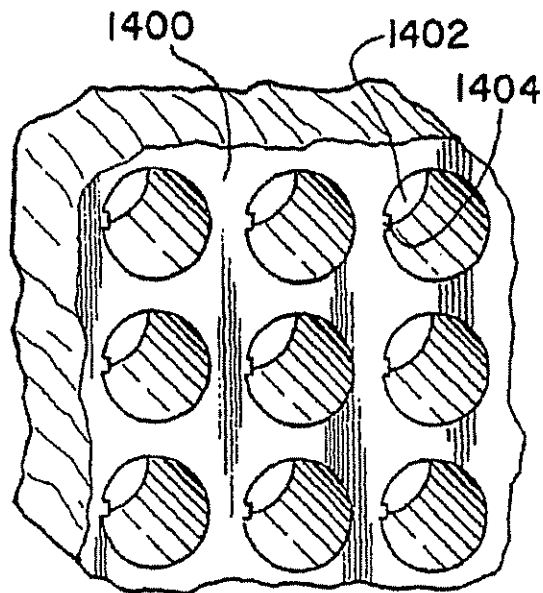

Fig. 14